

SB Series

DIRECT DRIVE BLOWER COIL

SUPERIOR
REX



SBHD

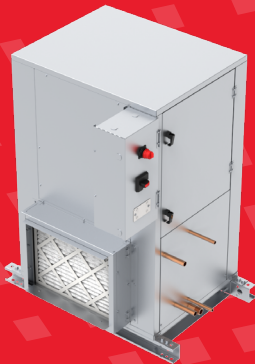

SBVD



ENGINEERING GUIDE

TABLE OF CONTENTS

FEATURES AND BENEFITS	3
CONSTRUCTION FEATURES	5
APPLICATIONS	6
COIL AND FILTER DATA	7
COILS AND STATIC PRESSURE DATA	8
ELECTRIC HEAT	10
FAN PERFORMANCE CURVES	12
DIMENSIONAL DATA	15
ELECTRICAL & WEIGHT DATA	20
GUIDE SPECIFICATIONS	21
NOTES	23



NOTES

- Superior Rex offers Selection Software, the industry’s first web-based rating and selection program for complete unit and coil selection.
- See your representative or visit our website at www.superiorrex.com for more information.
- Some drawings are not shown in this catalog. Drawings are not for installation purposes.
- ETL Report Number 103539254CRT-001.
- All data herein is subject to change without notice.

FEATURES AND BENEFITS

DESIGNED FOR MAXIMUM FLEXIBILITY

Both Horizontal and Vertical Direct Drive Blower-Coils are designed to maximize flexibility of selection and installation.

The units will exceed the stringent quality standards of the institutional market, while remaining cost competitive in the light commercial segment of the market.

COMPONENT OPTIONS

The extensive variety of standard options available on the SBHD & SBVD units are where you find the versatility to fit any HVAC system designer's needs.

Options include mixing boxes with standard low leak dampers, high efficiency filter sections for 2" prefilter and 4" final filter and blow thru electric heat with single point power connection. All Electric Heat units are listed with ETL as an assembly and carry the cETLus label.

Disconnects and fusing mean easier coordination between mechanical and electrical trades.

Direct drive fans eliminate noise and reduce maintenance time caused by belts.

All SBHD and SBVD direct drive blower-coils have the option of foil faced or closed cell foam insulation.

COIL OPTIONS

Coil options allow for 3, 4 or 6 row cooling coils. Water coils have optional circuiting that can be used to reduce Water Pressure Drop, which may also allow for pipe size reductions and lower material cost. Hot Water or Standard Steam coils may be placed in the Preheat or Reheat position.

QUALITY PRODUCT

SBHD and SBVD direct drive blower-coils are built from 18 gauge galvanized steel. This metal surpasses the ASTM 125 hour salt spray test for corrosion and rust. Standard insulation is 1 inch thick fiberglass, complying with UL 181 and NFPA 90A.

All units, with or without Electric Heat, are cETLus listed and labeled. All wiring is in compliance with NEC, assuring safety and quality for the owner.

BEST IN CLASS PERFORMANCE

Superior Rex direct drive blower-coils feature class leading airflow, coil capacity, and pressure capabilities. The single and dual blower configuration options for the size 30 and 40 units also allow for greater flexibility when configuring for sound and performance.

LOWER INSTALLED COST

All SBHD or SBVD direct drive blower-coils are shipped completely assembled, reducing field installation time and labor. All units are thoroughly inspected and tested prior to shipment, eliminating potential problems at startup. Standard wiring allows for single point power connection and all wiring is in compliance with NEC, ensuring safety and quality.

A wide variety of fan discharge configurations allow for increased flexibility and easier installation on the job site, resulting in cost reductions by eliminating expensive elbows, etc.

FEATURES AND BENEFITS

STANDARD FEATURES

Construction

- Galvanized steel cabinet construction, minimum 18 gauge
- 1" thick fiberglass insulation
- 1" supply duct collars
- Gasketed, removable access panels sized for easy handling
- IAQ galvanized steel drain pan (not included with heating-only units)
- Left and right hand arrangement

Fan Assembly

- Forward curved (double width, double inlet) fans
- Statically and dynamically balanced
- Solid steel shafting

Fan Motor and Drive

- Directly driven motor and blower
- Electronically commutated single and three phase motors with electronic protection

Electrical Control

- Single speed motor controls accessible from exterior of control enclosure
- Three different control options to choose from: o Variable single-speed with manual adjustment o Variable multi-speed with manual adjustment o Proportional speed (2-10VDC, 0-10VDC or 4-20mA remote signal) with external adjustment

Coils

- Coils are designed, manufactured and tested by Superior Rex
- AHRI 410 certified and labeled
- 1/2" O.D. seamless copper tubes
- High efficiency aluminum surface for optimizing heat transfer, pressure drop and carryover
- Mechanically expanded copper tubes leak tested to a minimum 450 PSIG air pressure underwater
- 450 PSIG working pressure at 200 °F
- Evaporator coils are factory sealed and charged with a minimum of 5 PSIG nitrogen or refrigerated dry air
- Steam coils rated at 15 PSIG maximum operating pressure at about 35 °F
- 0.016" tube wall thickness (0.025" on steam)

Filters and Filter Rack

- Hinged side access flat filter rack
- Standard size 2" nominal throwaway filters
- Filter rack designed to accept 2" filters

Electrical

- Fan motor wired and terminated to J-Box
- All units cETLus listed in compliance with UL/ANSI Standard 1995

OPTIONAL FEATURES

Construction

- IAQ stainless steel drain pan with 1" MPT galvanized pipe outlet
- External rubber-in-shear or spring type vibration isolators, hangers, or floor mount
- Scrim reinforced foil faced insulation
- Closed cell foam insulation
- Hinged access panels with lift and turn fasteners
- Base rails with rigging slots factory assembled and installed
- Auxiliary (secondary) drain connections

Fan Motor and Drive

- Directly driven motor and blower
- Electronically commutated single and three phase motors with electronic protection

Coils

- 3, 4 and 6 row chilled water or DX coils
- 1 and 2 row hot water or standard steam coils
- Heating coil in preheat or reheat position
- Coil connections opposite handing
- Stainless steel coil casings
- Automatic air vents on water coils
- Heat pump compatible cooling coils
- 0.025" tube wall thickness

Filters

- 2" pleated filter
- Spare throwaway or pleated filters
- High efficiency filter rack with 2" and 4" filters

Inlet Damper Section

- Factory assembled and installed
- Heavy gauge galvanized steel formed blade dampers
- Low leak dampers with extruded vinyl blade seals and flexible metal jamb seals
- Parallel blade operation
- Interconnecting damper linkage

Electrical

- Door interlocking disconnect switch (non-fused)
- Hand-Off-Auto (HOA) switch
- Main fusing

Electrical Heat Section

- Factory mounted electric heater with single point power connection, cETLus listed as an assembly

CONSTRUCTION FEATURES

MODEL SBHD

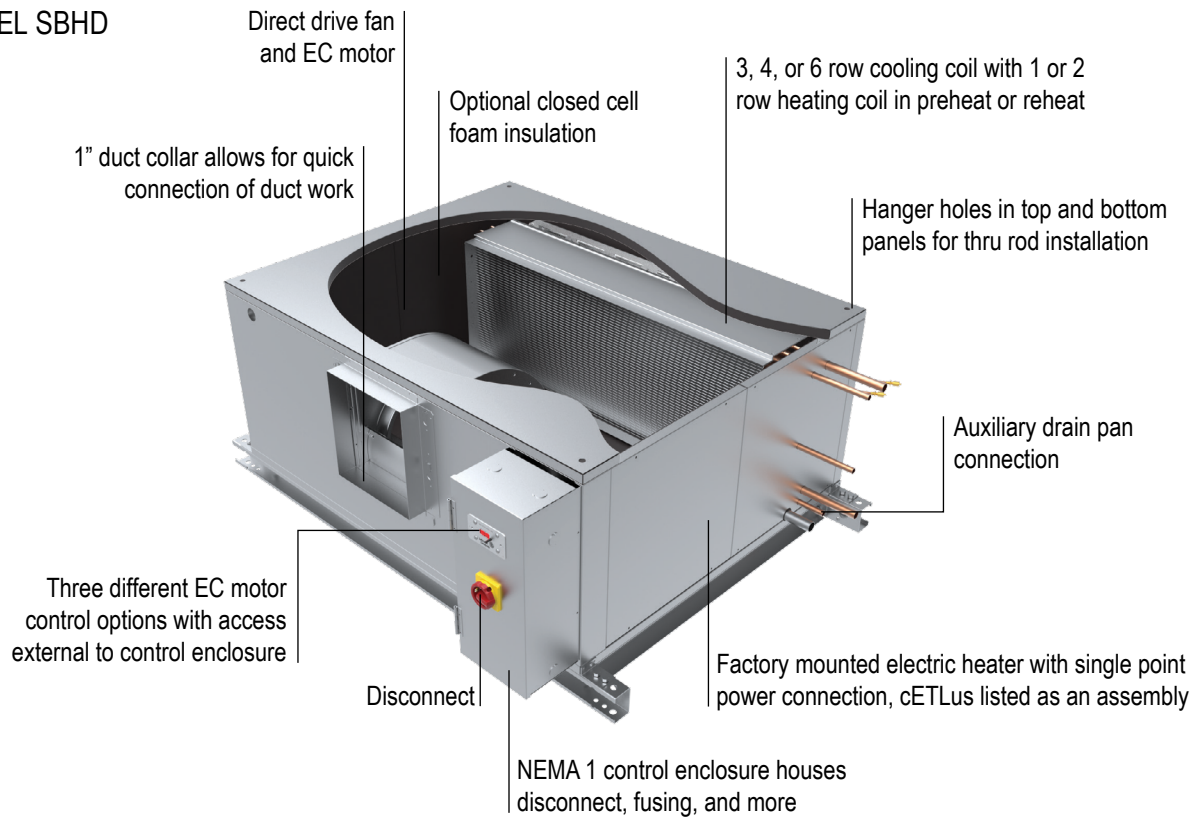

MODEL SBVD

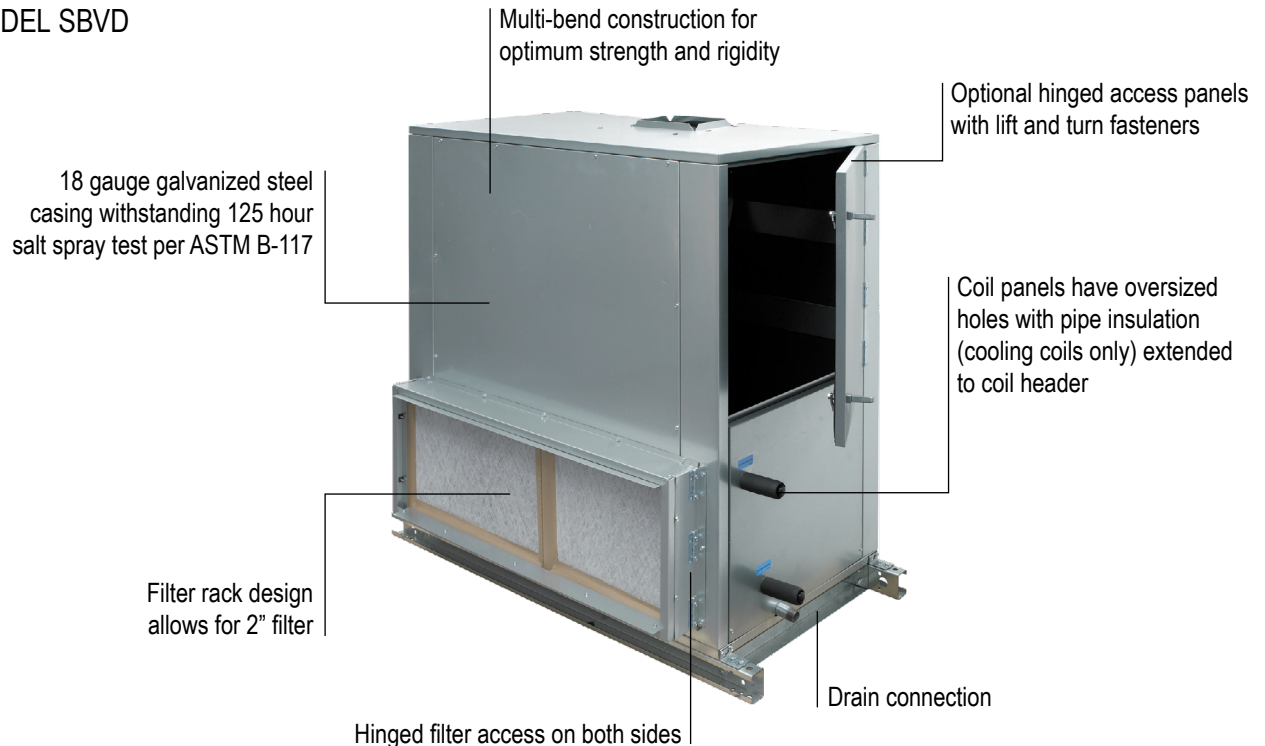

APPLICATIONS

APPLICATION CONSIDERATIONS

Model SBHD & SBVD Direct Drive Blower-Coils offer a wide range of application flexibility, while maintaining a simple, easy to install unit design. These units are intended to provide comfort cooling and heating within a small footprint. They may be applied in many types of building structures including schools, office buildings, hospitals, condominiums, assisted living facilities, apartments or stores. Applications can be constant or variable volume with several control options. There are many applications the SBHD & SBVD Direct Drive Blower-Coils can be utilized based on the control option selected. Some examples are listed below.

Single-Speed:

- Constant Volume
- Field Balanced
- Manually Adjustable
- Direct Expansion (DX) Split Systems
- Static Environments (such as service areas)
- Available with All Other Catalog Coil Configurations

Multi-Speed:

- Four Discrete Speeds (High-Medium-Low-Idle)
- Field Balanced
- Manually Adjustable
- Functional with Multiple Operators:
 - Building Management System (BMS)
 - Thermostats
 - 3-Speed Switch
- Static Environments (such as service areas)
- Great for Setting E.H. Minimum CFM

Variable-Speed:

- Multiple Remote Signal Options:
 - 0 – 10VDC
 - 2 – 10VDC
 - 4 – 20mA
- BMS Compatible
- Upstream of Variable-Air-Volume (VAV) Systems
- Constant Pressure
- BMS Turn down for Energy Efficiency

ACOUSTICS

Control of noise within both occupied and unoccupied spaces has become increasingly important to designers and building owners/occupants. Proper consideration must be given to placement of indoor air conditioning units, particularly in the occupied space. Inherent flexibility of the fan and coil combination in the vertical configuration allows application in sound-sensitive areas. In such instances, a fan running at a low speed with a high capacity coil normally yields satisfactory results. It also may be desirable to select a larger nominal capacity unit and operate it at a less than nominal airflow for further acoustic benefit. Being able to choose between single or dual blower configurations for the Size 30 and 40 units

allows for greater flexibility when trying to optimize the selection for sound and performance. The enhanced control options also allow for a quieter turn down. The direct drive design eliminates any noise issues caused by squeaky belts. Three phase motors are recommended for sound sensitive applications to avoid potential single phase motor hum.

INSTALLATION

These floor mounted or ceiling hung units can be installed with external vibration isolation on a base rail (SBHD or SBVD) or hanger rods (SBHD only) at the corner points. This requires flex connections at the corner brackets, ductwork, electrical connections and piping connections. One of the most important and basic IAQ issues is condensate management. The first step to trouble-free operation is proper installation. It is very important that the unit be mounted high enough so that the condensate drain from the unit may be properly trapped. Please refer to the SBHD & SBVD IOM Manual at www.superiorrex.com for specifics on this issue. As with all HVAC systems, these units should be installed according to all applicable ASHRAE standards, SMACNA and local code requirements. When selected and installed properly the units are seismically certified.

OPERATING LIMITATIONS

Superior Rex Direct Drive Blower-Coil Units offer unmatched performance capabilities across a broad range of airflow and static pressure requirements.

Units must not be operated above maximum fan speed or unit airflow as listed in the Fan Performance section of this catalog. Unit operation at greater than maximum fan speed could drastically reduce bearing life and may result in a catastrophic wheel failure.

Operating at greater than the maximum allowable airflow in the cooling mode may result in unsatisfactory operation due to moisture carry over from the coil. In addition, it is often not economical to operate a unit at its maximum fan speed due to the greater motor power requirements.

Units with electric heat should not be operated with leaving air temperature greater than 104°F (40°C), to prevent excessive leaving air temperatures and electric heat limit trips. A hydronic (or steam) coil and electric heat should not be operated simultaneously to prevent excessive leaving air temperatures and limit trips. Electric heat units are equipped with a high limit lockout switch that disables the electric heater if the temperature of the hydronic coil is greater than 104°F (40°C).

Water coils must not be operated above a fluid velocity of 8 ft./sec. to reduce the possibility of velocity induced erosion and flow noise. Water coils must not be operated below a fluid velocity of 1 ft./sec. to prevent degraded coil performance caused by laminar flow. These high or low fluid flow rates may not be included in the AHRI coil certification.

COIL AND FILTER DATA

Unit Size	Coil Face Area	2" Flat Filters (Quantity) & Size	Filter Face Area
08	2.1 (0.20)	(1) 15.75 x 19.75 x 2 (400 x 502 x 51)	2.2 (0.20)
12	2.7 (0.25)	(1) 15.75 x 24.75 x 2 (400 x 629 x 51)	2.7 (0.25)
16	3.5 (0.33)	(2) 15.75 x 19.75 x 2 (400 x 502 x 51)	4.3 (0.40)
20	4.9 (0.46)	(1) 15.75 x 19.75 x 2 (400 x 502 x 51) (1) 15.75 x 24.75 x 2 (400 x 629 x 51)	4.9 (0.46)
30	6.5 (0.60)	(2) 24.75 x 15.75 x 2 (629 x 400 x 51) (1) 24.75 x 19.75 x 2 (629 x 502 x 51)	8.8 (0.82)
40	8.4 (0.78)	(3) 24.75 x 19.75 x 2 (629 x 502 x 51)	10.2 (0.95)

NOTES:

1. Standard filters are 2" throwaway.
2. Filter sizes are nominal and standard size, measure in inches (millimeters).
3. Coil and filter face areas are measured in square feet (square meters).
4. Cooling and heating coils have same face area.

COILS AND STATIC PRESSURE DATA

COILS

Superior Rex offers hot water, chilled water and direct expansion (DX) coils for specific application with all Model SBHD and SBVD direct drive blower-coils. AHRI 410 certified and labeled, and strict on-site inspection before, during, and after installation guarantees the highest quality and performance available.

STANDARD FEATURES

- Coils are designed, manufactured and tested by Superior Rex
- AHRI 410 certified and labeled
- 1/2" O.D. seamless copper tubes
- High efficiency aluminum fin surface for optimizing heat transfer, pressure drop and carryover
- Mechanically expanded copper tubes leak tested to a minimum 450 PSIG air pressure under water
- Manual air vent plug on all water coils
- Copper ODM sweat connections
- 450 PSIG working pressure at 200°F
- Evaporator coils are factory sealed and charged with a minimum of 5 PSIG nitrogen or refrigerated dry air
- Refrigerant coils are provided with distributor (metering device field-provided)
- Steam coils rated at 15 PSIG maximum operating pressure at about 35°F
- 0.016" tube wall thickness (0.025" on steam)

OPTIONAL FEATURES

- Stainless steel coil casings
- Automatic air vents on water coils
- Heat pump compatible cooling coils
- 0.025" tube wall thickness



COILS AND STATIC PRESSURE DATA

COMPONENT STATIC PRESSURE LOSS – INCHES W.G.

Unit Size	Nominal CFM	Cabinet	Filter (2" T/A)	Coil					Mixing Box	Electric Heat Section
				1 Row	2 Row	3 Row	4 Row	6 Row		
08	600	0.05	0.08	0.03	0.05	0.12	0.16	0.24	0.02	0.01
	700	0.07	0.11	0.04	0.07	0.15	0.20	0.31	0.03	0.02
	800	0.09	0.15	0.04	0.09	0.19	0.25	0.38	0.04	0.02
	900	0.11	0.19	0.05	0.11	0.23	0.30	0.46	0.05	0.02
	1000	0.14	0.23	0.06	0.12	0.27	0.35	0.54	0.06	0.02
12	1000	0.06	0.14	0.04	0.08	0.17	0.24	0.36	0.04	0.02
	1100	0.08	0.17	0.50	0.10	0.19	0.28	0.42	0.05	0.02
	1200	0.09	0.20	0.06	0.11	0.22	0.32	0.47	0.06	0.02
	1300	0.11	0.24	0.06	0.12	0.25	0.36	0.54	0.07	0.02
	1400	0.12	0.28	0.07	0.14	0.28	0.40	0.60	0.08	0.03
16	1400	0.08	0.11	0.05	0.09	0.20	0.26	0.37	0.07	0.02
	1500	0.09	0.13	0.05	0.10	0.22	0.30	0.42	0.08	0.02
	1600	0.10	0.15	0.06	0.11	0.25	0.33	0.46	0.09	0.02
	1700	0.11	0.17	0.06	0.12	0.27	0.36	0.51	0.10	0.02
	1800	0.13	0.19	0.07	0.14	0.30	0.39	0.56	0.11	0.03
20	1600	0.07	0.11	0.03	0.07	0.15	0.18	0.30	0.03	0.02
	1800	0.09	0.14	0.04	0.08	0.18	0.22	0.36	0.04	0.02
	2000	0.11	0.18	0.05	0.10	0.21	0.26	0.41	0.05	0.02
	2200	0.13	0.21	0.06	0.11	0.25	0.31	0.48	0.06	0.02
	2400	0.16	0.26	0.07	0.13	0.28	0.35	0.55	0.07	0.02
30	2600	0.11	0.09	0.05	0.09	0.19	0.27	0.41	0.06	0.02
	2800	0.12	0.11	0.05	0.10	0.22	0.30	0.43	0.07	0.02
	3000	0.14	0.12	0.06	0.12	0.24	0.34	0.47	0.08	0.02
	3200	0.16	0.14	0.07	0.13	0.27	0.34	0.53	0.09	0.03
	3400	0.18	0.16	0.07	0.14	0.29	0.38	0.58	0.10	0.03
40	3600	0.13	0.13	0.05	0.10	0.21	0.30	0.43	0.06	0.02
	3800	0.14	0.15	0.06	0.11	0.22	0.33	0.47	0.06	0.02
	4000	0.16	0.16	0.06	0.12	0.24	0.35	0.51	0.07	0.02
	4200	0.18	0.18	0.07	0.13	0.26	0.38	0.55	0.08	0.03
		0.19	0.20	0.07	0.14	0.28	0.41	0.59	0.08	0.03

NOTES:

1. All static pressures are at nominal CFM.
2. Coil static pressure for standard coil, 10FPI at 80/67 EAT and 45° EWT with 10° rise.
3. For 8, 12 or 14 FPI, refer to Selection Software®, available at www.superiorrex.com.
4. Filter static pressure based on 50% loaded filter.
5. If pleated filters are used in lieu of throwaway, the filter static pressure loss is 0.35.

ELECTRIC HEAT

STANDARD FEATURES

- Flanged construction for direct unit mounting, in blow thru configuration
- Listed for zero clearance installation
- Meets National Electrical Code requirements
- Ni-Chrome wire in ceramic insulators
- Stainless steel element terminals and hardware
- Element support brackets on maximum 3 1/2" centers
- Solid cover with continuous full height hinge
- Over temperature protection
- All internal wiring rated for 105°C minimum
- Airflow switch
- Incoming line power distribution block
- cETL Listed in compliance with UL/ANSI Standard 1995
- Single point power connection
- Heater factory mounted to unit with cETL listing as an assembly

OPTIONAL FEATURES

- Main incoming power disconnect (non-fused)
- Fusing (main) (per stage)
- Magnetic contactors wired for disconnecting operation
- Fan control package with heater interlock contacts (required for single point power connection)

USEFUL FORMULAS

$$kW^* = \frac{CFM \times \Delta T \times 1.085^{**}}{3413}$$

$$1\emptyset \text{ AMPs} = \frac{kW \times 1000}{Volts}$$

* 1kW = 3413 BTU/H

** Capacity at sea level

Altitude Considerations:

Reduce by 0.034 for each 1000 ft. of altitude above sea level.

Example: 5000 ft./1000 ft. = 5

5 x 0.034 = 0.17

1.085 - 0.17 = 0.915

ELECTRICAL CALCULATIONS INFORMATION

1. Refer to MCA/MOP Calculator at www.superiorrex-hvac.com for MCA and/or MOP calculations.
2. Non-Fused Door Interlock Disconnect Switch shall be sized according to MCA.
3. Main Fusing shall be sized according to MOP.

HEATER AMP CALCULATION

Voltage	AMPS per kW
115/1	8.70
208/1	4.81
230/1	4.35
277/1	3.61
208/3	2.78
230/3	2.51
480/3	1.26



ELECTRIC HEAT

Unit Size			Electric Heat kW Limits															
			Unit Size															
			08		12		16		20		30 (Single Blower)		40 (Single Blower)		30 (Dual Blower)		40 (Dual Blower)	
			Min	Max	Min	Max	Min	Max	Min	Max	Min	Max	Min	Max	Min	Max	Min	Max
Single Phase	115	kW	3.0	5.0	3.0	5.0	3.0	5.0	3.0	5.0	3.0	5.0	3.0	5.0	5.0	5.5	5.0	5.5
		AMPS	26.1	43.5	26.1	43.5	26.1	43.5	26.1	43.5	26.1	43.5	26.1	43.5	3.5	47.8	43.5	47.8
	208	kW	3.0	9.0	3.0	9.0	3.0	9.0	3.0	9.0	3.0	9.0	3.0	9.0	6.0	11.0	6.0	11.0
		AMPS	14.4	43.3	14.4	43.3	14.4	43.3	14.4	43.3	14.4	43.3	14.4	43.3	28.8	52.9	28.8	52.9
	230	kW	3.0	11.0	3.0	11.0	3.0	11.0	3.0	11.0	3.0	11.0	3.0	11.0	6.0	13.0	6.0	13.0
		AMPS	13.0	47.8	13.0	47.8	13.0	47.8	13.0	47.8	13.0	47.8	13.0	47.8	26.1	56.5	26.1	56.5
	277	kW	3.0	13.0	3.0	13.0	3.0	13.0	3.0	13.0	3.0	13.0	3.0	13.0	6.0	17.0	6.0	17.0
		AMPS	10.8	46.9	10.8	46.9	10.8	46.9	10.8	46.9	10.8	46.9	10.8	46.9	21.7	61.4	21.7	61.4
Three Phase	208	kW	3.0	13.0	3.0	16.0	3.0	16.0	3.0	16.0	3.0	16.0	3.0	16.0	6.0	24.0	6.0	24.0
		AMPS	8.3	36.1	8.3	44.4	8.3	44.4	8.3	44.4	8.3	44.4	8.3	44.4	16.7	66.6	16.7	66.6
	230	kW	3.0	13.0	3.0	18.0	3.0	18.0	3.0	18.0	3.0	18.0	3.0	18.0	6.0	26.0	6.0	26.0
		AMPS	7.5	32.6	7.5	45.2	7.5	45.2	7.5	45.2	7.5	45.2	7.5	45.2	15.1	65.3	15.1	65.3
	480	kW	3.0	13.0	3.0	20.0	3.0	20.0	3.0	26.0	3.0	26.0	3.0	26.0	6.0	38.0	6.0	38.0
		AMPS	3.8	16.3	3.8	25.1	3.8	25.1	3.8	32.6	3.8	32.6	3.8	32.6	7.5	47.7	7.5	47.7

NOTES:

1. Factory certified submittals available upon request.
2. Standard heater kW limits are maximum per unit size and voltage.
3. Heater should be sized for a maximum leaving air temperature of 104 °F.

FAN PERFORMANCE CURVES

UNIT SIZE 08 & 12, SINGLE PHASE SINGLE BLOWER

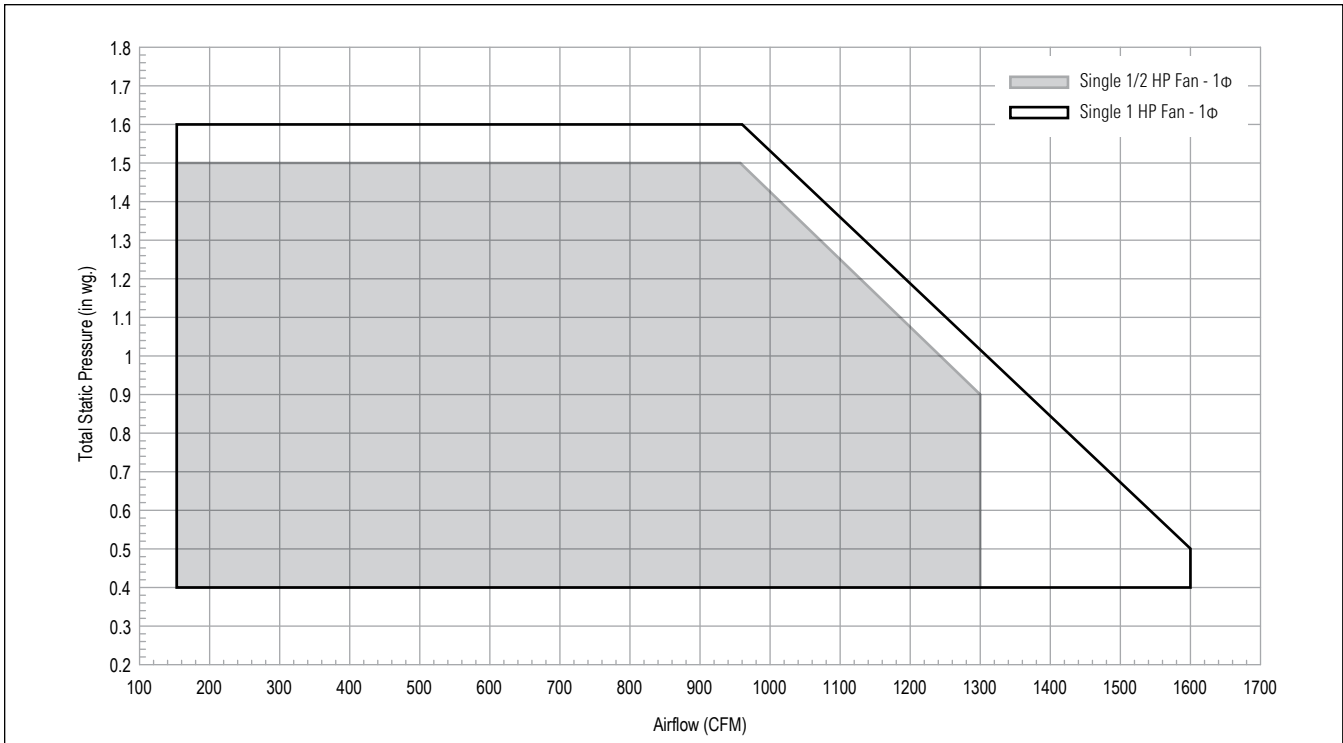

UNIT SIZE 08 & 12, THREE PHASE SINGLE BLOWER

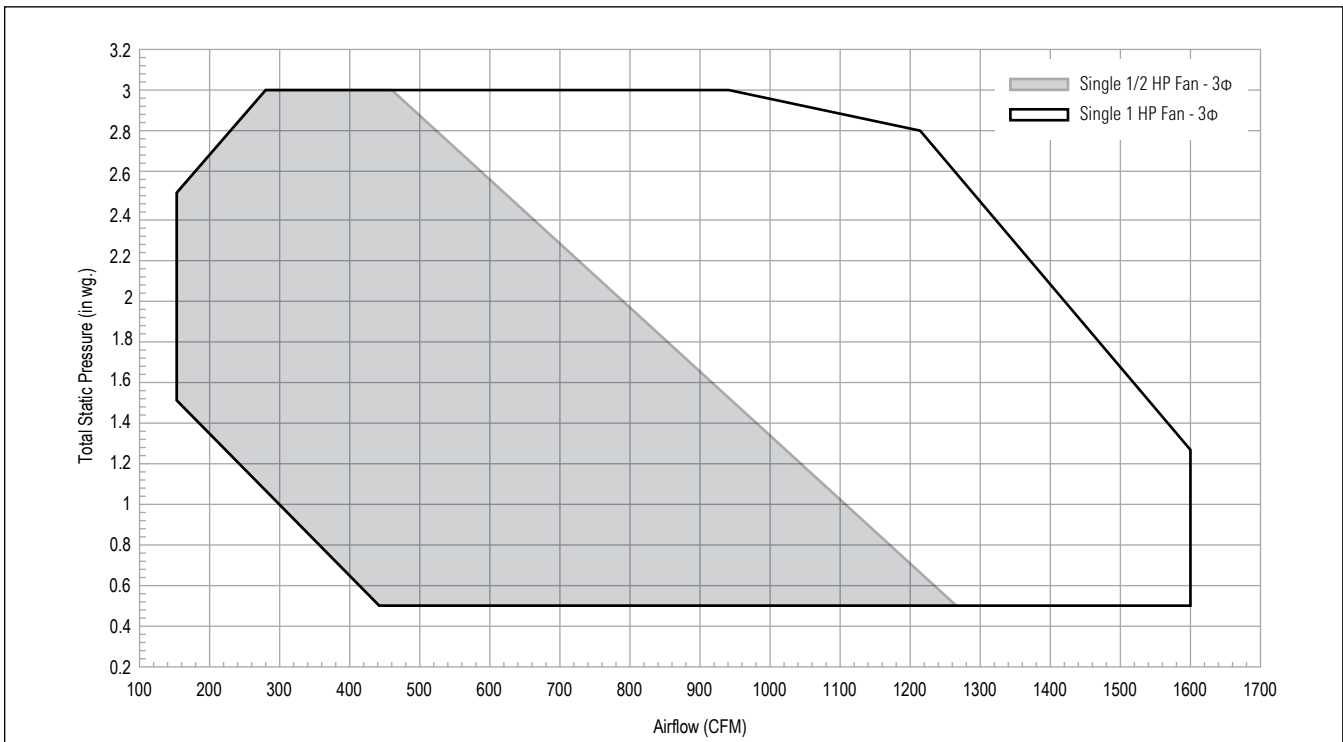

FAN PERFORMANCE CURVES

UNIT SIZE 16, 20, 30 & 40 SINGLE PHASE SINGLE BLOWER

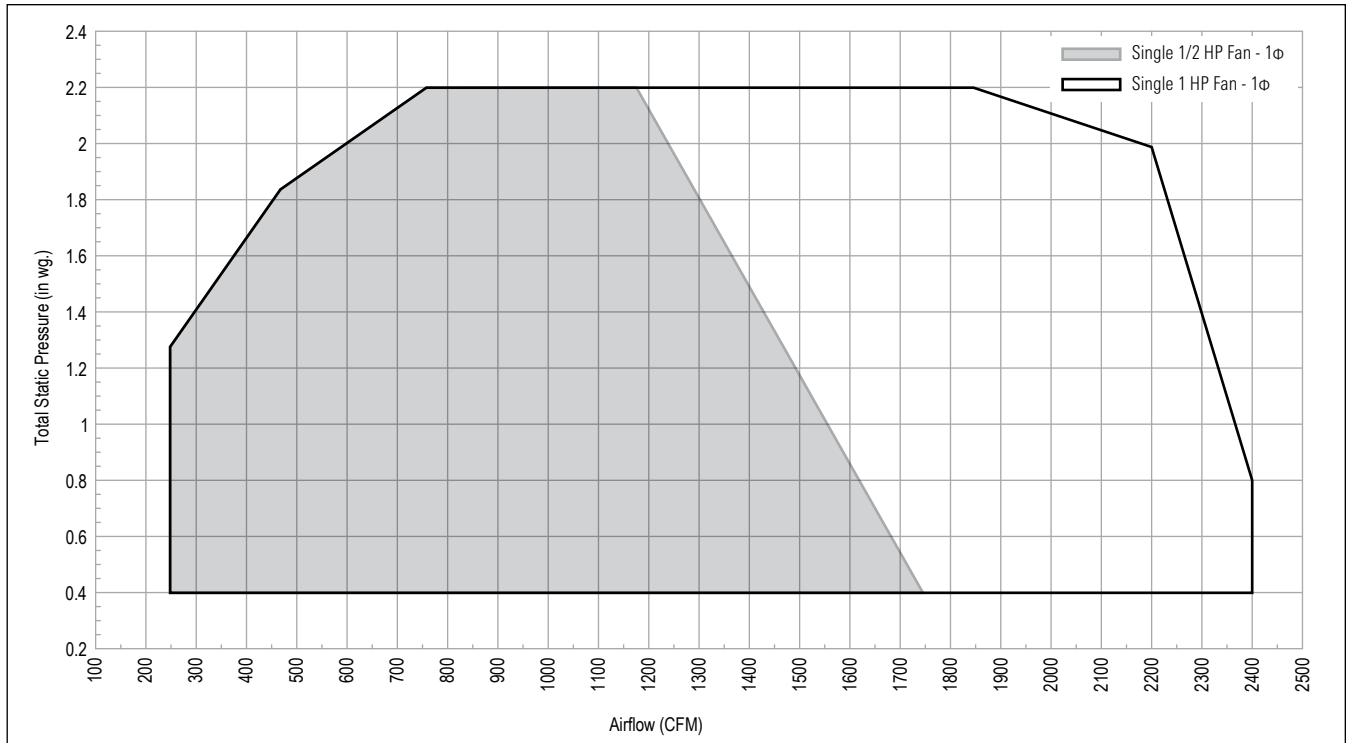

UNIT SIZE 16, 20, 30 & 40 THREE PHASE SINGLE BLOWER

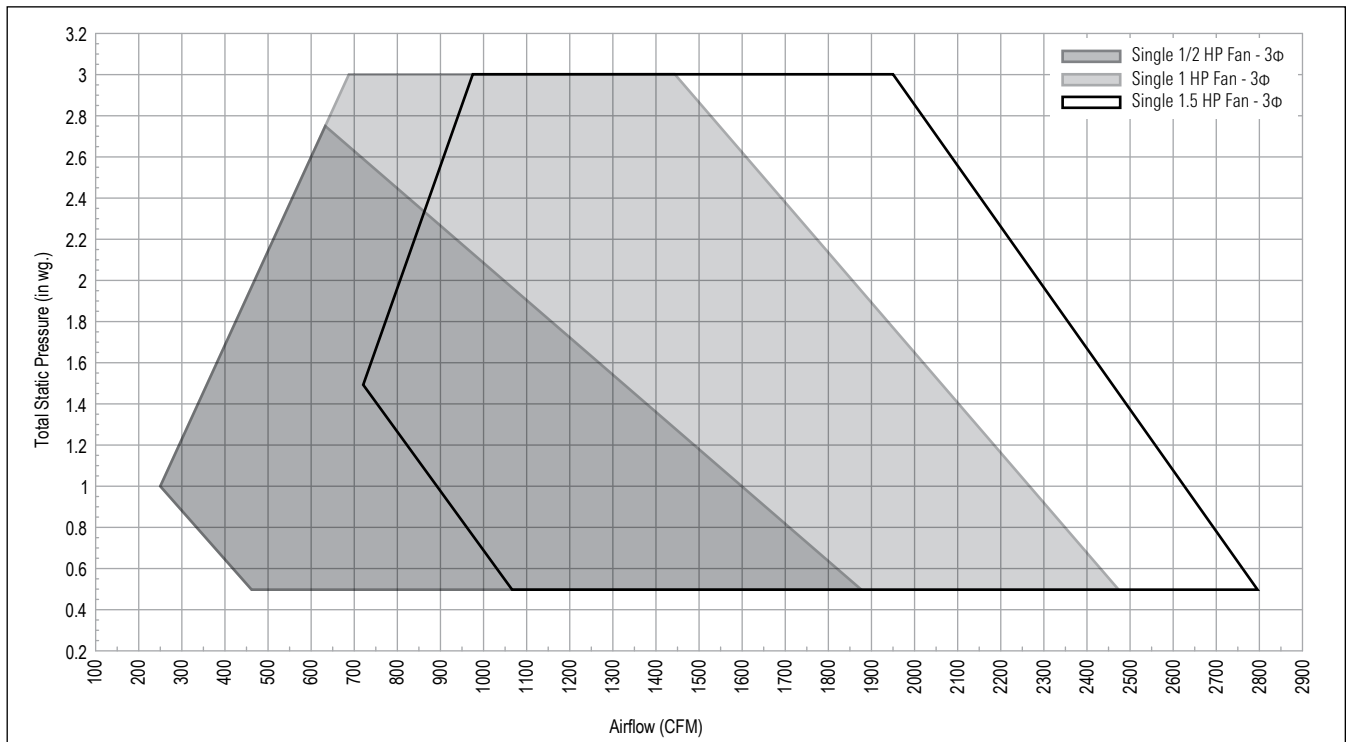

FAN PERFORMANCE CURVES

UNIT SIZE 30 & 40 SINGLE PHASE DUAL BLOWER

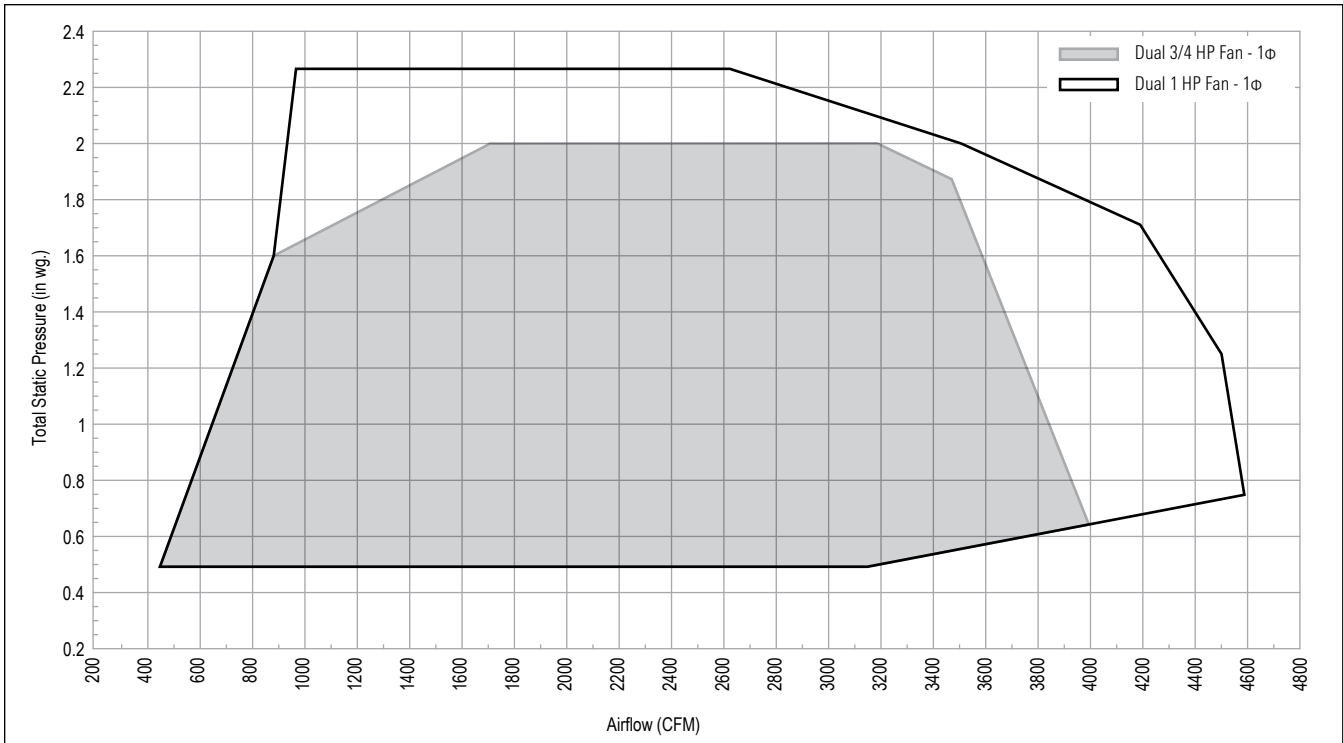

UNIT SIZE 30 & 40 THREE PHASE DUAL BLOWER

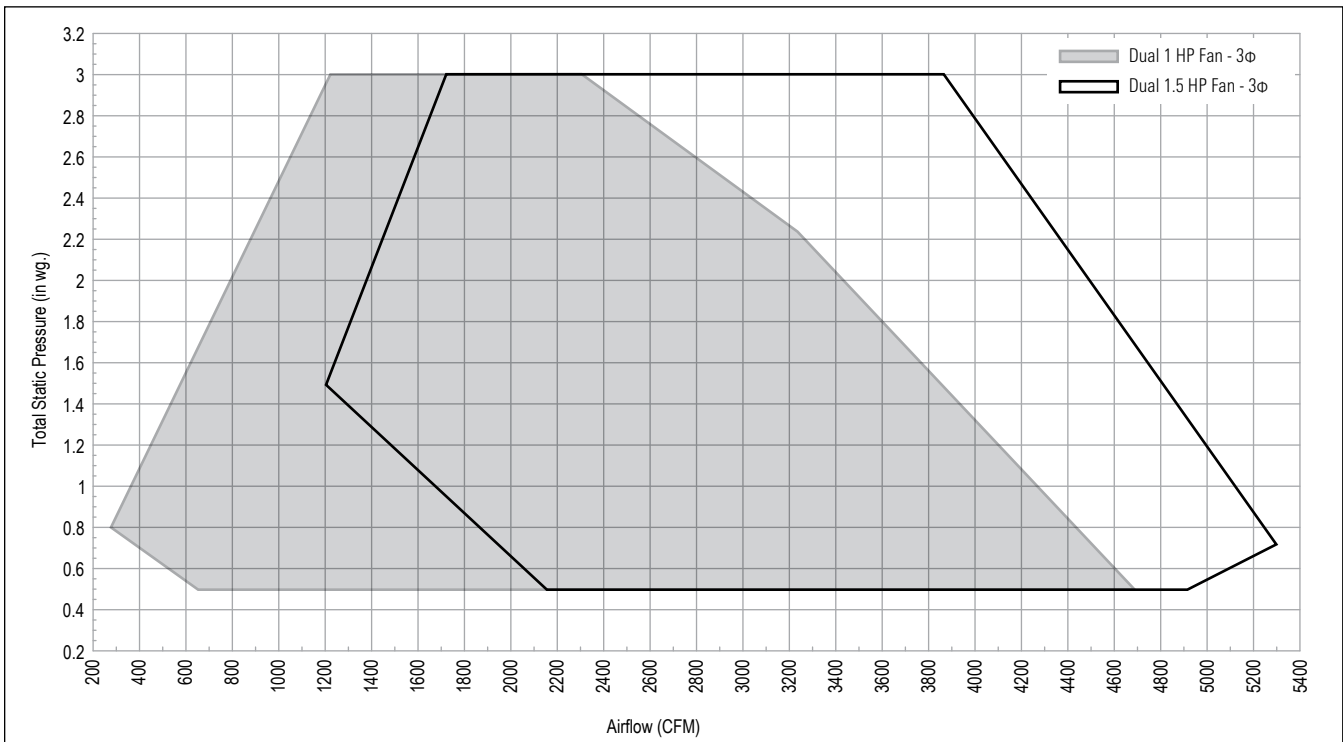

DIMENSIONAL DATA

MODEL SBHD, SBVD, BLOW THRU ELECTRIC HEAT

Drawings are not to scale and are not for installation purposes.

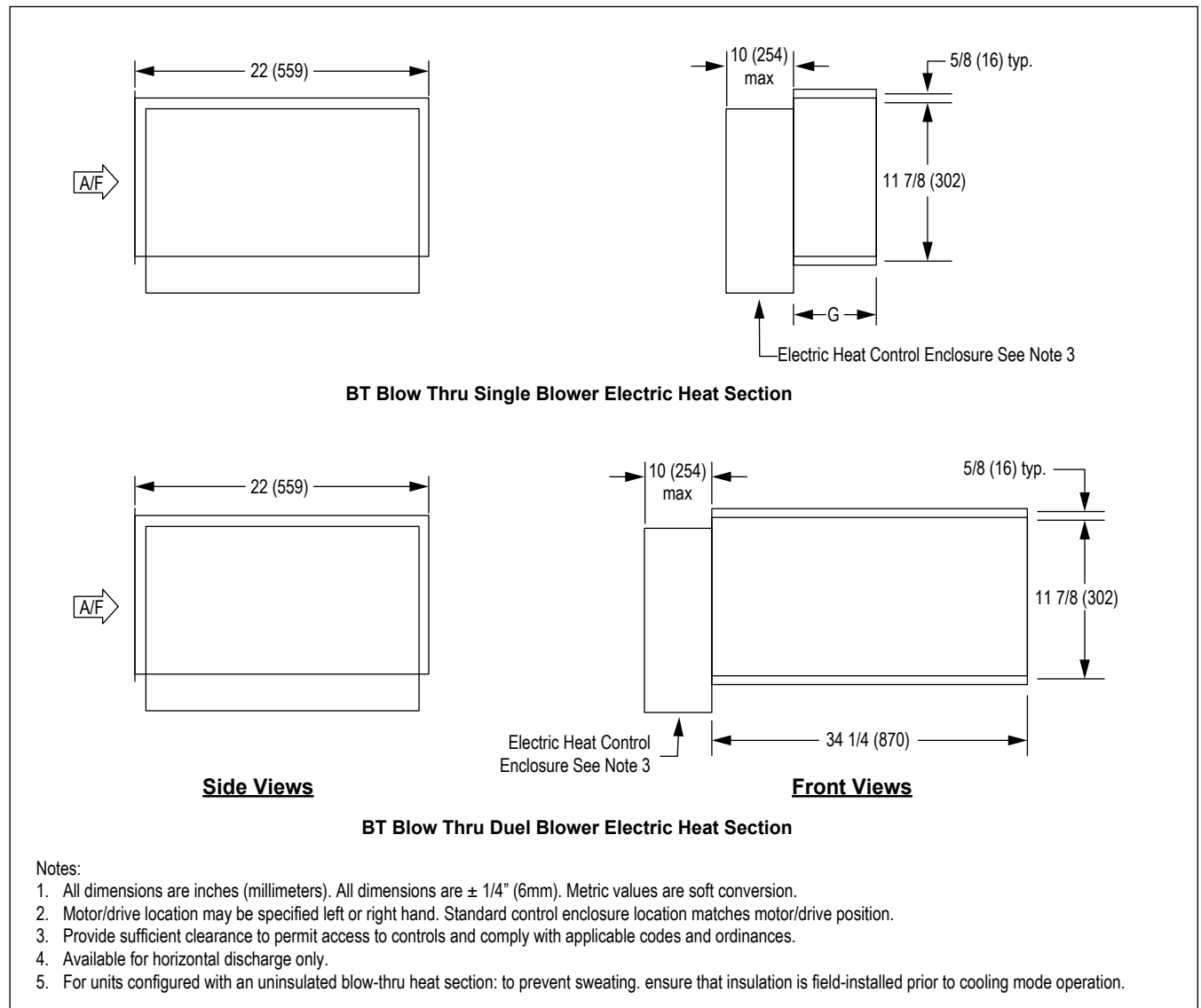

Unit Size	Weight lbs (kg)		G
	Single Blower	Dual Blower	
08	45 (20)	-	8 3/4 (222)
12	45 (20)	-	8 3/4 (222)
16	45 (20)	-	10 3/4 (273)
20	45 (20)	-	10 3/4 (273)
30	45 (20)	100 (45)	10 3/4 (273)
40	45 (20)	140 (64)	10 3/4 (273)

DIMENSIONAL DATA

SINGLE BLOWER CONFIGURATION

Drawings are not to scale and are not for installation purposes.

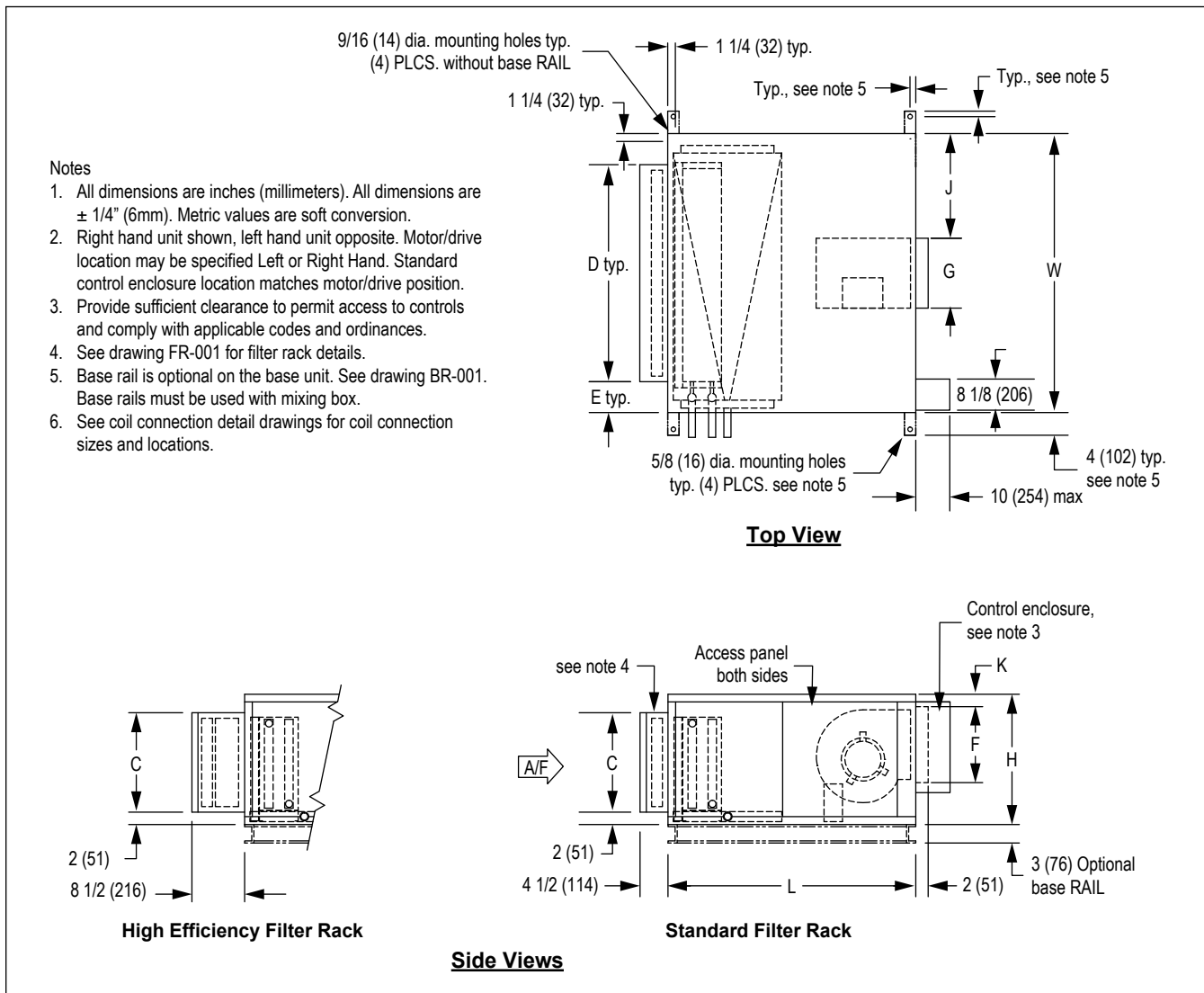

Size	Fan Size	L	W	H	C	D	E	F	G	J	K
08	9 x 6 (229 x 152)	40 (1016)	30 (762)	21 (533)	16 (406)	20 (508)	5 (127)	10 3/8 (264)	8 3/8 (213)	10 7/8 (276)	2 (51)
12	9 x 6 (229 x 152)	40 (1016)	36 (914)	21 (533)	16 (406)	25 (635)	5 1/2 (140)	10 3/8 (264)	8 3/8 (213)	13 7/8 (352)	2 (51)
16	10 x 8 (254 x 203)	40 (1016)	44 (1118)	21 (533)	16 (406)	39 1/2 (1003)	2 1/4 (57)	11 1/2 (292)	10 5/8 (270)	16 5/8 (422)	2 (51)
20	10 x 8 (254 x 203)	40 (1016)	50 (1270)	21 (533)	16 (406)	44 1/2 (1130)	2 3/4 (70)	11 1/2 (292)	10 5/8 (270)	19 5/8 (498)	2 (51)
30	10 x 8 (254 x 203)	46 (1168)	59 (1499)	30 (762)	25 (635)	51 (1295)	4 (102)	11 1/2 (292)	10 5/8 (270)	24 1/4 (616)	9 3/4 (248)
40	10 x 8 (254 x 203)	46 (1168)	68 (1727)	30 (762)	25 (635)	59 (1499)	4 1/2 (114)	11 1/2 (292)	10 5/8 (270)	28 5/8 (727)	9 3/4 (248)

DIMENSIONAL DATA

SINGLE BLOWER CONFIGURATION

Drawings are not to scale and are not for installation purposes.

Notes

1. All dimensions are inches (millimeters). All dimensions are $\pm 1/4"$ (6mm). Metric values are soft conversion.
2. Right hand unit shown, left hand unit opposite. Motor/drive location may be specified Left or Right Hand. Standard control enclosure location matches motor/drive position.
3. Provide sufficient clearance to permit access to controls and comply with applicable codes and ordinances.
4. Flat filter rack may be located at unit inlet as required. See drawing FR-001 for filter rack details.
5. Base rail is optional on the base unit. See drawing BR-001. Base rails must be used with mixing box.
6. See coil connection detail drawings for coil connection sizes and locations.

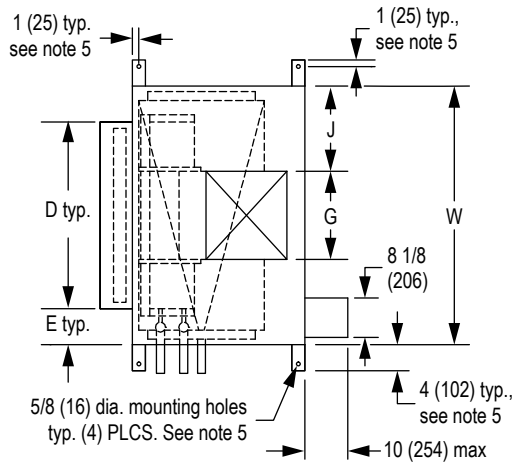

Top View

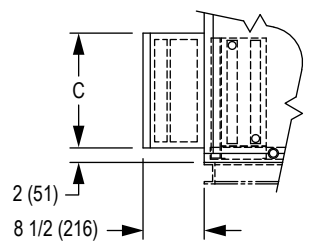

High Efficiency Filter Rack

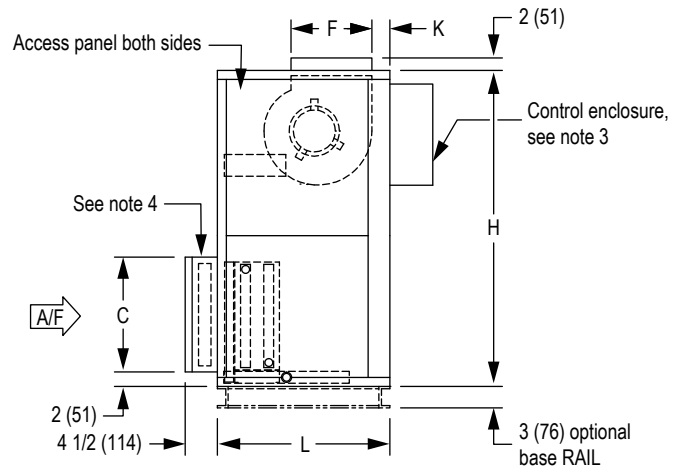

Standard Filter Rack

Side Views

Size	Fan Size	L	W	H	C	D	E	F	G	J	K
08	9 x 6 (229 x 152)	24 (610)	30 (762)	44 (1118)	16 (406)	20 (508)	5 (127)	10 3/8 (264)	8 3/8 (213)	10 7/8 (276)	2 1/2 (64)
12	9 x 6 (229 x 152)	24 (610)	36 (914)	44 (1118)	16 (406)	25 (635)	5 1/2 (140)	10 3/8 (264)	8 3/8 (213)	13 7/8 (352)	2 1/2 (64)
16	10 x 8 (254 x 203)	24 (610)	44 (1118)	44 (1118)	16 (406)	39 1/2 (1003)	2 1/4 (57)	11 1/2 (292)	10 5/8 (270)	16 3/4 (425)	2 1/2 (64)
20	10 x 8 (254 x 203)	30 (762)	50 (1270)	50 (1270)	16 (406)	44 1/2 (1130)	2 3/4 (70)	11 1/2 (292)	10 5/8 (270)	19 3/4 (502)	2 1/2 (64)
30	10 x 8 (254 x 203)	30 (762)	59 (1499)	56 (1422)	25 (635)	51 (1295)	4 (102)	11 1/2 (292)	10 5/8 (270)	24 1/4 (629)	10 (254)
40	10 x 8 (254 x 203)	30 (762)	68 (1727)	59 (1499)	25 (635)	59 (1499)	4 1/2 (114)	11 1/2 (292)	10 5/8 (270)	28 3/4 (730)	10 (254)

DIMENSIONAL DATA

MODEL SBHD, SBVD STANDARD MIXING BOX

Drawings are not to scale and are not for installation purposes.

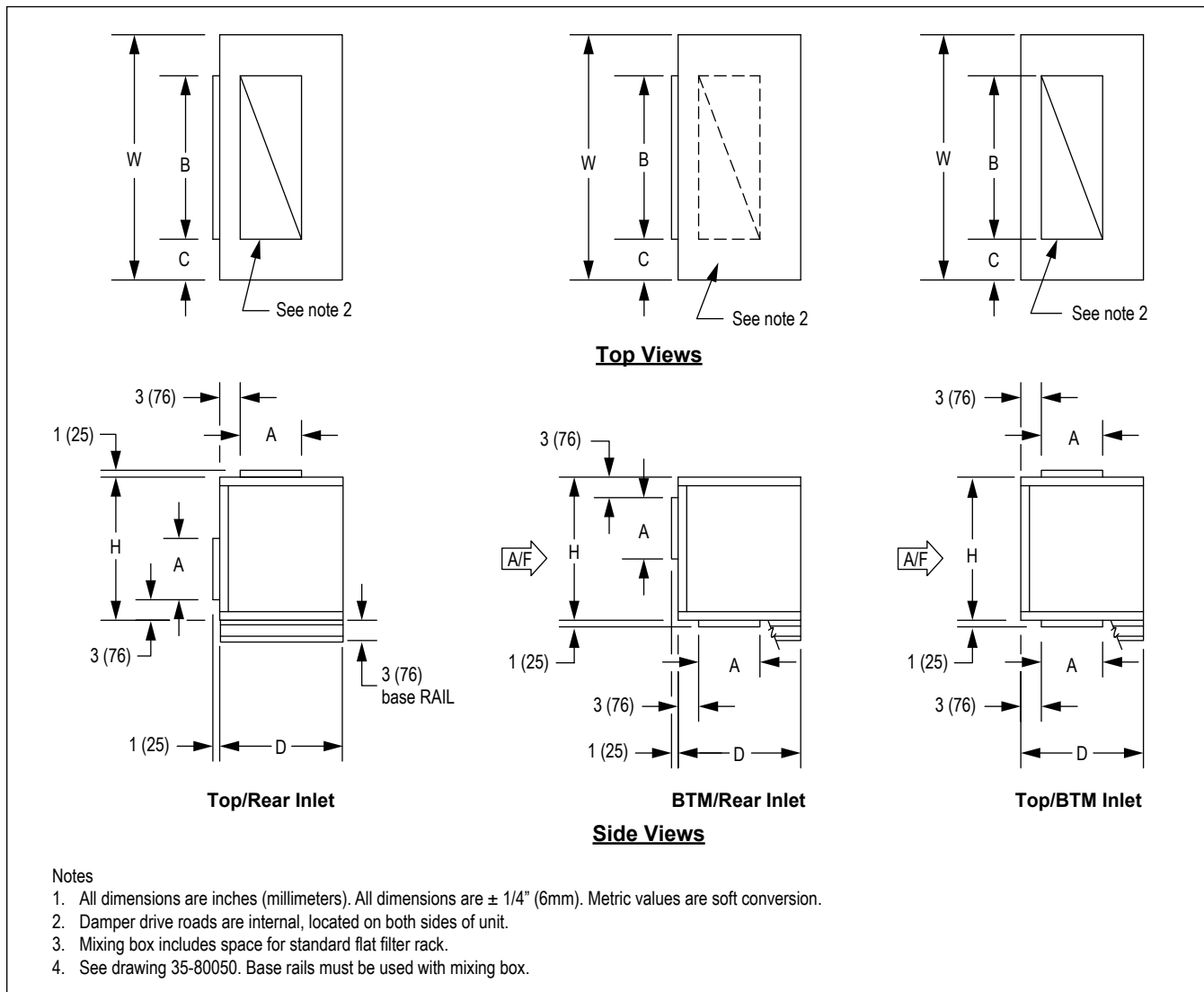

Unit Size	H	W	A	B	C	D
08	21 (533)	30 (762)	9 (229)	18 (457)	6 (152)	18 (457)
12	21 (533)	36 (914)	9 (229)	24 (610)	6 (152)	18 (457)
16	21 (533)	44 (1118)	9 (229)	30 (762)	7 (178)	18 (457)
20	21 (533)	50 (1270)	12 (305)	36 (914)	7 (178)	21 (533)
30	30 (762)	59 (1499)	12 (305)	45 (1143)	7 (178)	21 (533)
40	30 (762)	68 (1727)	15 (381)	48 (1219)	10 (254)	24 (610)

DIMENSIONAL DATA

MODEL SBHD, SBVD STANDARD FLAT FILTER RACK

Drawings are not to scale and are not for installation purposes.

Notes

1. All dimensions are inches (millimeters). All dimensions are $\pm 1/4"$ (6mm). Metric values are soft conversion.
2. Flat filter rack may be located at unit inlet as required.
3. Standard rack will accept nominal 1" or 2" thick filters.
4. High eff. rack will accept nominal 2" and/or 4" thick filters.
5. High eff. rack not available on units with filter rack.
6. 1" duct connection space provided on entering side of rack for connection of field ductwork.
7. Hinged cover provided on both sides of externally mounted filter racks. Internal standard filter racks have pivoting bar type filter retainer.
8. See individual unit submittal drawings for location of filter rack on unit.

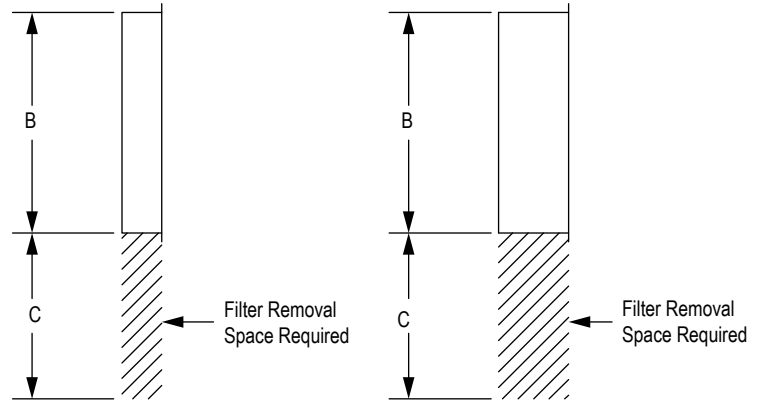

Top Views

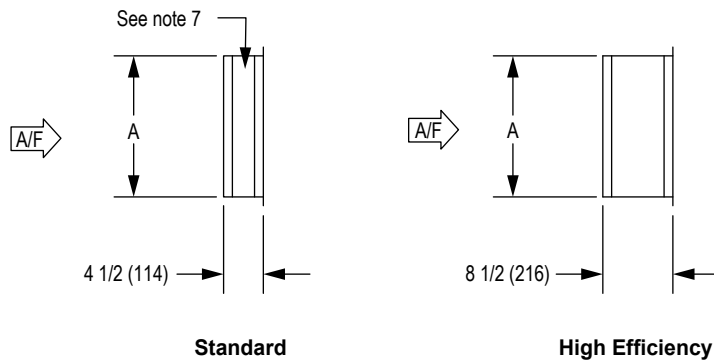

Standard

High Efficiency

Side Views

Unit Size	A	B	C	Qty & Size Filters
08	16 (406)	20 (508)	20 (508)	(1) 16 x 20
12	16 (406)	25 (635)	25 (635)	(1) 16 x 25
16	16 (406)	39 1/2 (1003)	20 (508)	(1) 16 x 20
20	16 (406)	44 1/2 (1130)	25 (635)	(1) 16 x 20 (1) 16 x 25
30	25 (635)	51 (1295)	25 (635)	(1) 16 x 25 (1) 20 x 25
40	25 (635)	59 (1499)	25 (635)	(1) 20 x 25

ELECTRICAL & WEIGHT DATA

MOTOR ELECTRICAL DATA

Horsepower	Maximum Motor Amperage						
	Voltage/Phase						
	115/1	208/1	230/1	277/1	208/3	230/3	480/3
1/2	7.7	5.0	5.0	4.1	2.0	2.0	1.0
1	12.8	9.4	9.4	6.9	3.7	3.7	1.7
1 1/2	19.23	14.63	14.63	11.03	4.4	4.4	2.2
2	25.63	18.83	18.83	13.83	7.43	7.43	3.43
3	--	--	--	--	8.83	8.83	4.43

NOTES:

1. Actual motor nameplate AMPs may vary, but will not exceed values shown.
2. Consult factory for applications requiring special motors.
3. Amp values are total amp values for (2) motors.

UNIT WEIGHT DATA

Component	Unit Size								
	08	12	16	20	30 (Single Blower)	40 (Single Blower)	30 (Dual Blower)	40 (Dual Blower)	
Base Unit	115 (52)	133 (60)	152 (69)	175 (79)	287 (130)	305 (139)	357 (162)	375 (170)	
Mixing Box	46 (21)	54 (25)	65 (30)	90 (41)	105 (48)	105 (48)	162 (74)	162 (74)	
Blow Thru Electric Heater	42 (19)	42 (19)	55 (25)	55 (25)	55 (25)	125 (57)	55 (25)	125 (57)	
Coil Rows	1 Row - Dry	12 (5)	14 (6)	17 (8)	21 (10)	26 (12)	26 (12)	32 (15)	32 (15)
	1 Row - Wet	14 (6)	16 (7)	20 (9)	25 (11)	32 (15)	32 (15)	41 (19)	41 (19)
	2 Row - Dry	17 (8)	21 (10)	26 (12)	33 (15)	42 (19)	42 (19)	52 (24)	52 (24)
	2 Row - Wet	21 (10)	26 (12)	32 (15)	42 (19)	54 (24)	54 (24)	69 (31)	69 (31)
	3 Row - Dry	23 (10)	28 (13)	35 (16)	45 (20)	57 (26)	57 (26)	72 (33)	72 (33)
	3 Row - Wet	29 (13)	36 (16)	44 (20)	59 (27)	75 (34)	75 (34)	95 (43)	95 (43)
	4 Row - Dry	29 (13)	35 (16)	44 (20)	57 (26)	73 (33)	73 (33)	91 (41)	91 (41)
	4 Row - Wet	37 (17)	45 (20)	56 (25)	74 (34)	96 (44)	96 (44)	121 (55)	121 (55)
	6 Row - Dry	40 (18)	49 (22)	62 (28)	81 (37)	104 (47)	104 (47)	132 (60)	132 (60)
6 Row - Wet	52 (24)	64 (29)	81 (37)	106 (48)	138 (63)	138 (63)	178 (81)	178 (81)	

NOTES:

1. Unit weight data is shipping weight in pounds (kilograms).

MOTOR/DRIVE WEIGHT DATA

Type	Motor HP				
	1/2	1	1 1/2	2	3
Single Phase	13	19	38	38	--
Three Phase	14	18	43	36	106

NOTES:

1. Unit weight data is shipping weight in pounds (kilograms).

GUIDE SPECIFICATIONS

GENERAL

Furnish and install Superior Rex® Model SBHD & SBVD Blower Coil Units where indicated on the plans and specifications. Units shall be completely factory assembled and tested and shipped as one piece except where noted.

All units shall be capable of meeting or exceeding the scheduled capacities for cooling, heating and air delivery. All unit dimensions for each model and size shall be considered maximums.

All units shall be of "draw-thru" design with coils, fans, motor, and drain pan completely contained within the unit cabinet.

Electric heat to be in the blow-thru configuration.

Units shall be cETL listed in compliance with UL/ANSI Std. 1995.

All unit coils shall meet or exceed the scheduled cooling and heating capacity, selected and rated in accordance with AHRI 410.

CONSTRUCTION

All units shall be fabricated of minimum 18 gauge galvanized steel, able to withstand a 125 hour salt spray test per ASTM B-117. Panels shall be die-formed "multibend" construction for optimum strength and rigidity.

All exterior panels shall be single wall insulated with 1" thick fiberglass insulation, rated for a maximum air velocity of 5000 f.p.m.

Optional: Single wall with 1" thick, 1.6 pound per cubic foot density scrim reinforced foil faced insulation.

Optional: Single wall with 1" thick closed cell foam insulation.

Insulation must meet all requirements of ASTM C1071 (including C665), UL181 for erosion, and carry a 25/50 rating for flame spread/smoke developed per ASTM E-84, UL723 and NFPA 90A. In addition to using adhesive complying with NFPA 90A, the insulation shall incorporate a secondary mechanical fastener attached to the unit casing wall. Adhesive as the only method of fastening the insulation to the casing is not acceptable.

All access panels shall be fully insulated and attached with standard fasteners on at least two opposite sides. No single access panel shall be larger than 30" x 36" for safety and ease of handling. No coil or drain piping or electrical connections shall pass through any access panel. Each unit shall be furnished with a one-piece heavy gauge.

G90 steel or optional IAQ stainless steel drain pan with welded corner construction. Drain pan shall be insulated with minimum 1/8" closed cell foam. All units shall be provided with 9/16" diameter hanger rod holes in the top and bottom panels for "through-bolt" type suspension installation.

Optional: Spring type unit mounting vibration isolators shall be provided by the unit manufacturer.

Optional: Rubber-in-shear type unit mounting vibration isolators shall be provided by the unit manufacturer.

Optional: Units to have factory assembled and installed base rails with rigging slots.

All units shall have a minimum 1" duct collar on both the discharge and return.

FAN & MOTOR ASSEMBLY

All units shall be furnished with double inlet forward curved centrifugal blowers statically and dynamically balanced for smooth operation. Blower wheels shall be mounted directly on the motor shaft. Belt driven blowers are not acceptable.

Fan motors shall be electronically commutated with thermal overload protection and a constant torque operation. RPM control shall not be acceptable. Motors shall feature permanently lubricated ball bearings and operate on three or single phase power.

All motors to be installed, factory programmed and wired to the control panel.

All motors shall be isolated, depending on motor size, via belly band or torsion flex mount to the blower housing.

All motor wiring is to be terminated in a junction box, external to the unit casing.

All motors to be operated by single-speed or multi-speed local or remote controller.

COILS

All unit coils shall be rated in accordance with AHRI 410.

All coils shall be 1/2" O.D. seamless copper tubes with collared aluminum fins. All tubes shall be mechanically expanded to provide an efficient bond between tube and fin. All water coils shall be provided with a manual air vent fitting to allow for coil venting. Valve core type vent fittings shall not be accepted.

All chilled water, hot water, and direct expansion (DX) coils shall have aluminum fins and 0.016" tube wall thickness.

All coils shall be hydrostatically tested with air under water at 450 PSIG minimum pressure and rated for a maximum of 450 PSIG working pressure at 200°F.

All steam coils shall have 0.025" tube wall thickness.

GUIDE SPECIFICATIONS

All steam coils shall be suitable for 15 PSIG maximum operating pressure.

Optional: Provide automatic air vents, in lieu of manual air vents.

Optional: Provide 0.025" tube wall thickness.

FILTER RACK ASSEMBLY

All units shall be furnished with a flat filter rack with hinged access on both sides designed to accept a 2" nominal standard sized filters. All units shall be provided with nominal 2" throwaway filters factory installed. One complete set of spare throwaway filters shall be provided for each unit.

Optional: Factory provided MERV 8 pleated filters.

Optional: Unit shall have a High Efficiency filter rack suitable for a pleated 2" MERV 8 and a pleated 4" MERV 11, MERV 14 or MERV 15 filter.

INLET DAMPER SECTION

Where shown on the plans, the unit manufacturer shall furnish a fully insulated mixing box section (factory assembled and installed inlet damper section) to be mounted next to the unit on base rail (unit & mixing box).

The mixing box section shall include heavy gauge formed steel blade dampers in a heavy gauge steel frame with extruded vinyl blade seals and flexible metal jamb seals. Damper drive linkage shall be factory furnished and installed by the unit manufacturer. A field furnished and installed damper actuator can be mounted directly to the damper shaft.

ELECTRICAL CONTROL

The unit fan motor shall be completely factory wired to an external electrical enclosure. Each unit shall include fan control package with 24 volt control voltage. Each unit shall include a motor control board, motor circuit fusing, control circuit transformer and terminal strip for connection of field wiring.

Motor Control Board Option 1: Motor control shall be provided by a single speed or proportional speed controller mounted on the exterior surface of the control box.

Opening the control box to adjust the fan speed shall not be required.

Motor Control Board Option 2: Four speed motor control shall be provided with potentiometer type adjustment. Unit to be compatible with three speed control thermostat.

Calibrated airflow curves shall be provided near the control box to aid in testing and balancing.

A main incoming power non-fused disconnect switch with lock-out tag-out ready feature shall be factory furnished and wired by the unit manufacturer for single point power connection.

ELECTRIC HEAT SECTION

Where shown on the plans, the unit manufacturer shall furnish an electric resistance heating assembly with the heating capacity, voltage and stages as shown in the schedule. The heater assembly shall be designed and rated for installation to the blower coil unit in the blow thru configuration without the use of duct extensions or transitions between the unit and the heater assembly. The heater assembly shall be factory assembled to the air handling unit and completely factory wired. The heater/unit assembly shall be listed for zero clearance meeting all N.E.C. requirements and be cETL listed in compliance with UL/ANSI Std. 1995.

All heating elements shall be open coil design using Ni-Chrome wire mounted in ceramic insulators and housed in an insulated heavy gauge galvanized steel housing. All elements shall terminate in a machine staked stainless steel terminal secured with stainless steel hardware. The element support brackets shall be spaced no greater than 3-1/2" on center. All internal wiring shall be rated for 105°C minimum.

All heaters shall include over temperature protection. All heaters shall include a non-adjustable airflow switch.

An incoming line power distribution block shall be provided. The power distribution block shall be designed to accept incoming power wiring capable of carrying 125% of the calculated load current.

In addition to the above, electric heaters shall include the following options:

- Main incoming power disconnect (non-fused)
- Main fusing
- Magnetic contactors wired for disconnecting operation

Electric heat section available uninsulated or with insulated double wall construction.

NOTES

NOTES

NOTES
